

E6XX

PPE EXPRESS DRYER (6)

NFPA 1851 COMPLIANT

PRODUCT SPECS

Machine Dimensions

Width (in) (Shipping)	54-5/8" (60")
Depth (in) (Shipping)	38" (48")
Height (in) (Shipping)	82" (86")
Clearance (Rear/Sides)	4" / 10" min.

Machine Weight

Crated Weight (lb)	1150
--------------------	------

Available Electrical

E612 - 2 WIRE	240V/1PH/60HZ - 30.1 A
E613 - 3 WIRE	208V/1PH/60HZ - 27.5 A
E633 - 3 WIRE	240V/3PH/60HZ - 19.6 A
E634 - 4 WIRE	208V/3PH/60HZ - 17.7 A

Recommended Fuse

E612/E613/E633	35 A
E634	30 A

Performance

AirFlow (cfm)	900
Heating (W)	6000

Included Equipment

Shelves	4
Gear Hangers	6
Glove Hangers	6

Capacity

Gear	Up to 6 Sets
Hose	200-300 ft

Warranty (yrs)

10

Note 1:

image w/o ducting

Note 2:

Available in Stainless
Options, contact for pricing



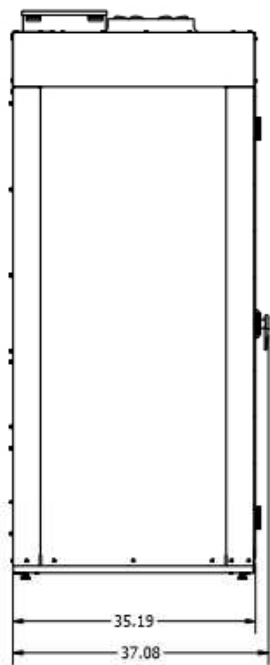
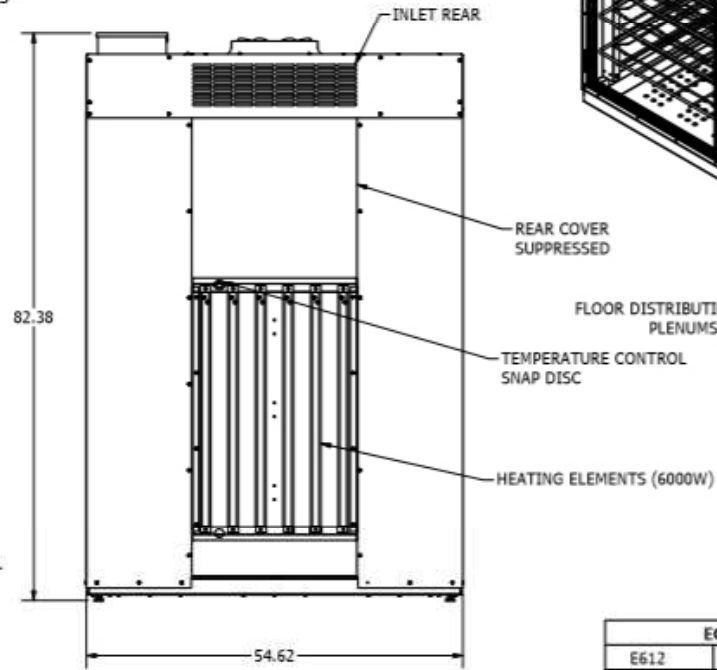
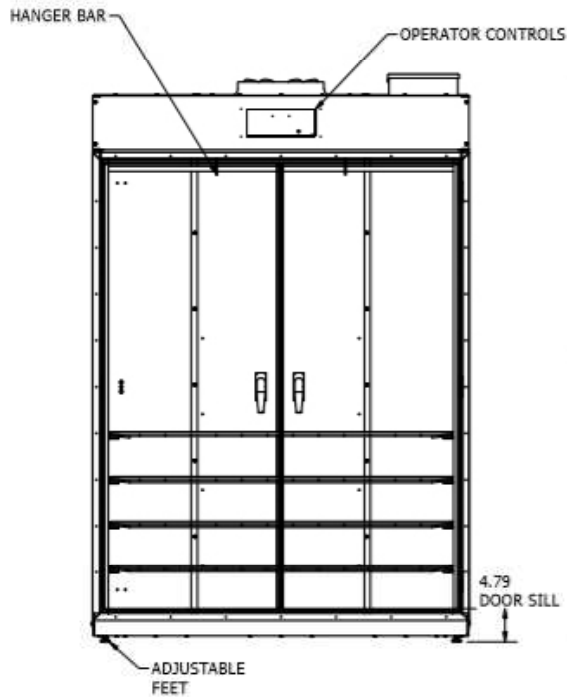
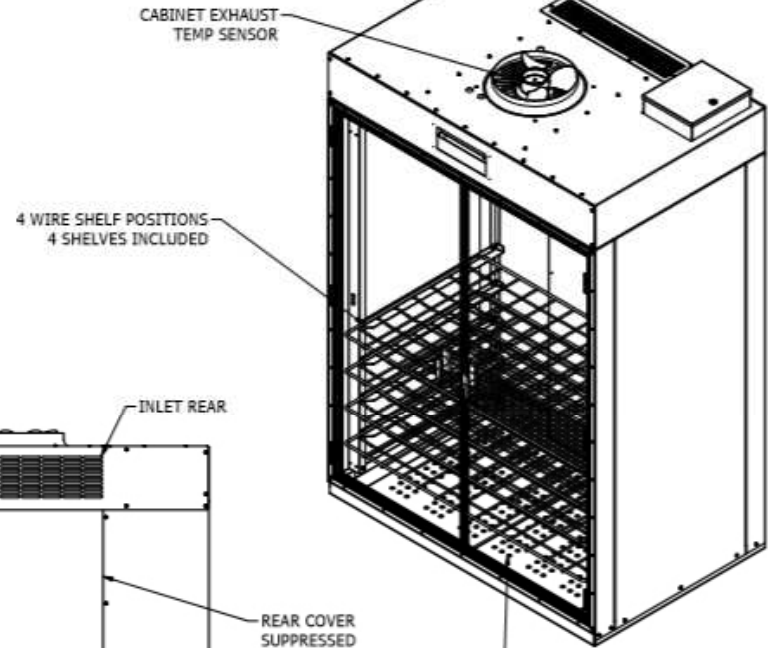
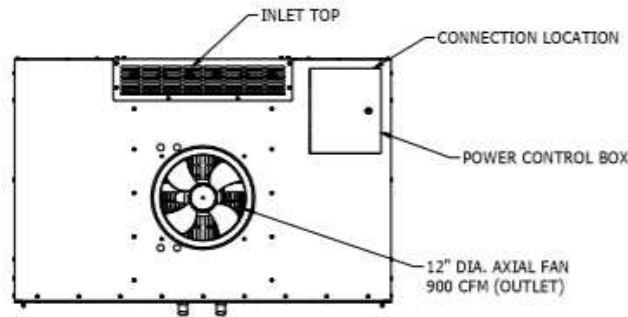

EQUIPMENT SPECIFICATIONS	
E612	240 V / 1 PH / 60 HZ, 30.1 A, 35 A FUSE
E613	208 V / 1 PH / 60 HZ, 27.5 A, 35 A FUSE
E633	240 V / 3 PH / 60 HZ, 19.6 A, 30 A FUSE
E634	240 V / 3 PH / 60 HZ, 17.7 A, 30 A FUSE
AIRFLOW	SUCTION - 900 CFM, AXIAL
HEATING	6 X 1000 W STRIP ELEMENT, WIRED FOR PHASE
DUCTING	MAX: 14" DIA., 20' RUN W/ DAMPER TYP: 12" DIA., 15' RUN W/ DAMPER MIN: 10" DIA., 15' RUN W/ DAMPER
CAPACITY	GEAR, UP TO 6 SETS. HOSE UP TO 4 SHELVES

DUCTING NOTES:

- 1) STANDARD ROOF COLLAR IS 14" DIA. TO 12", STEP DOWN FROM COLLAR TO 12" OR 10",
- 2) RECTANGULAR DUCT SHOULD BE 8"X16",
- 3) DUCT SHOULD HAVE MANUAL DAMPER (PIVOT) OR GUILLOTINE DAMPER 2-3' FROM OUTLET.

ELECTRICAL NOTES:

- 1) RECOMMENDED CONNECTION IS DISCONNECT FROM WALL W/ 3/4" LIQUID SEAL W/ METAL LINER. ALLOW 3' OF SLACK.

SHIPPING NOTES:

SHIPPING WEIGHT IS 1150LBS W/ CRATE. DIMS 46" X 62" X 90".

THIS DOCUMENT IS THE PROPERTY OF
CIRCUL-AIR CORP. INTERNATIONAL LTD.
ANY DISTRIBUTION OR REPRODUCTION WITHOUT
THE EXPRESSED WRITTEN PERMISSION IS
FORBIDDEN.

NFPA 1851 COMPLIANT



DESIGNED BY	FERWICK CDM	2020-05-07
CHECKED BY	FERWICK CDM	2020-05-07
DATE		
APPROVED BY	FERWICK CDM	2020-05-07
DATE	FERWICK CDM	2020-05-07

CIRCUL-AIR CORP. INTL.	
TITLE	
PPE EXPRESS DRYER (6) - STANDARD	
SIZE	DWG NO.
C	PPE-6 STANDARD
SCALE	REV
0.07 : 1	0
Sheet 1 of 1	